



<b>DIMENSIONS</b>	<b>1300x500x1000H mm</b>
<b>WEIGHT</b>	<b>650 kg</b>
<b>POWER</b>	<b>11 kW</b>
<b>VOLTAGE</b>	<b>230/400 V</b>
<b>LOADING</b>	<b>continuous</b>
<b>NUMBER OF REVOLUTIONS</b>	<b>63 rpm</b>

# TTC400i



**HYDRAULIC POWER UNIT**  
The hydraulic control unit is fitted with an 11 kW electric motor.

### DESCRIPTION

The **TTC400i** unit is a machine conceived and designed to shred long and skein-type metal swarf. It is a machine suitable for different applications, both for small treatment systems and for centralised systems.

The swarf loaded in the hopper is dismembered by a hooked arm which performs pre-shredding and conveys the swarf to the actual grinding point. The skein is then shredded and discharged from below.

Where there is a non-shreddable piece that interferes with the process, the machine automatically ejects it through a side container controlled by two air cylinders.

The unit is driven by a hydraulic motor powered by a control unit.

THE HOURLY PRODUCTION [m3/h] AND THE REDUCTION PERCENTAGE DEPEND ON THE TYPE OF SWARF.

### SUPPLY

- Structure and casing made of sturdy painted metal carpentry;
- Blades and counter-blades for shredding in anti-wear material;
- Automatic ejection system for non-shreddable pieces;
- Alternating direction shredding system;
- Arm to convey the swarf to the shredding inlet;
- Force control clutch;
- Hydraulic motor with hydraulic power unit.

### OPTIONAL

- Storage hopper for swarf loading;
- Automated hopper closure lid and consent microswitch;
- Ejected pieces separation sieve;
- Electrical control panel.

HOURLY PRODUCTION						
Q = 0.8 m3/h	BRASS	STEEL	ALUMINIUM	STAINLESS STEEL	COPPER	CAST IRON
<b>Δ density [kg/dm3]</b>	0.4	0.5	0.2	0.5	0.4	-
<b>Kg/h →</b>	320	400	200	400	320	-

THE DATA IN kg/h ARE APPROXIMATE AND IN ANY CASE DEPEND ON THE DENSITY OF THE SWARF, THE SHAPE, THE TYPE AND THE THICKNESS. THE DENSITY DATA CONSIDERED ARE HYPOTHETICAL, BASED ON AN EXPERIMENTAL AVERAGE OF THE DATA IN OUR POSSESSION. PRIOR TESTS CAN BE PERFORMED.



## SWARF CHARACTERISTICS & TECHNICAL NOTES

1. The long swarf can appear scattered or in skein agglomerations;
2. The swarf can be made of steel, iron, alloy steel (stainless), copper, brass (ecobross), aluminium,...
3. The swarf may contain some sporadic pieces (bar ends or headers, processed parts, ...) which depending on the size will be shredded or automatically ejected;
4. The loading process can be dosed by channel or by tipping from a container.

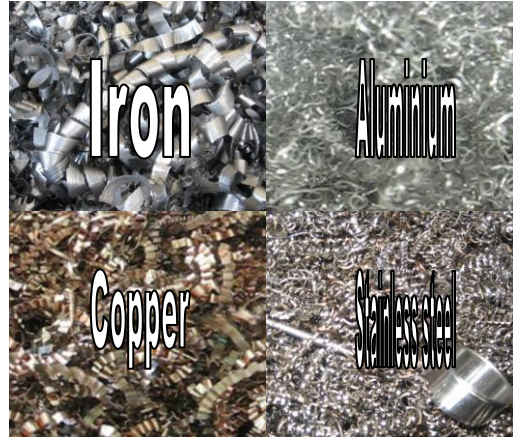

### APPLICATION ANALYSIS EXAMPLE

FROM A SKEIN-TYPE STEEL SAMPLE OF 400 LT, A VOLUME OF 80 LT WAS OBTAINED AFTER THE SHREDDING PROCESS.

### THE REDUCTION OF OCCUPIED VOLUME

## TECHNICAL FEATURES

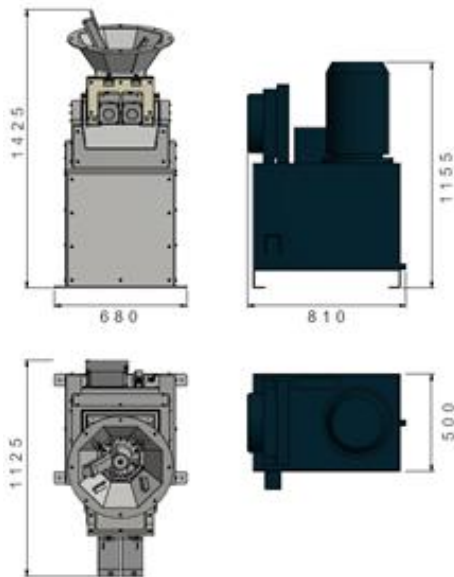

1. To confirm the production and volume reduction data, a specific test must be performed with the swarf in question, on the basis of which the machine is calibrated;
2. The rotor and the skein dismembering shaft are replaceable;
3. The number and shape of counter-blades to be applied to the shredder casing and to the hopper depend on the type of swarf;
4. The presence of pieces is not a problem for the shredder but slows down its hourly production.

## STORAGE HOPPER

Different types of hopper can be installed on top of the shredder, depending on the desired "lung" volume and loading methods. The hopper is complete with inspection door with safety microswitch and mechanical closure, to access the shredding area. If necessary, it is possible to install an automatic closing system of the loading inlet which prevents operation of the shredder, when open

## UNLOADING OUTLET

The photo on the side shows the unloading point of the shredded swarf and any ejected pieces.

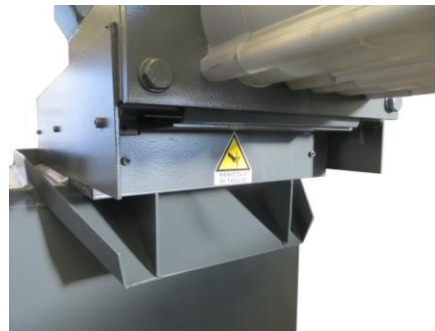

FAMA RESERVES THE RIGHT TO MAKE CHANGES TO THE PRODUCT WITHOUT NOTICE

FAMA RESERVES THE RIGHT TO MAKE CHANGES TO THE PRODUCT WITHOUT NOTICE

Uffici e Produzione / Offices and work: Via del Terziario, 20 36016 THIENE (VI) ITALY – Tel.0445 - 363950 Fax 0445 - 386068

Sede Legale/ Registered office: Via S. Antonio, 11 -- 36030 FARA VICENTINO (VI) Italy Tax Code/VAT No: 02290490248 Share Capital

€ 100,000.00 R.E.A. (Economic and Administrative Index) VI 220095 <http://www.famaproject.com> e-mail [info@famaproject.com](mailto:info@famaproject.com)

Last modification: 19/09/2019