



REV  
0.0

# T OIL FILTERS

COMMERCIAL SHEET



OIL MIST AND DUST

## SUPPLY

- T OIL SERIES FILTERS
- PRE-CHAMBER
- GALVANISED PERIMETER PANELLING
- MULTISTAGE PREFILTERS
- STANDARD COLOUR RAL 7016

## ACCESSORIES/OPTIONAL

- ELECTRIC PANEL
- ELECTRIC FAN
- AUTOMATIC OIL DRAIN
- CUSTOM COLOURING

## DESCRIPTION

The FAMA T series filter units are compact units with high efficiency, specially designed for the elimination of vapours and oil mists.

The system consists of two types of pre-filtration: one gravitational, obtained by changing the air speed inside the stilling chamber with flow deflectors, the second consisting of metal mesh filters, which are used to concentrate the oily vapours. This is followed by a filtration stage with soft fibreglass pockets with high filtration efficiency, particularly designed and continuously tested for the filtration of oily vapours and, as last and fourth stage, rigid pocket filters in category F9/H13.



Plug & Play



Compact

4.0

Industry 4.0  
Ready



Easy

maintenance



Easy maintenance

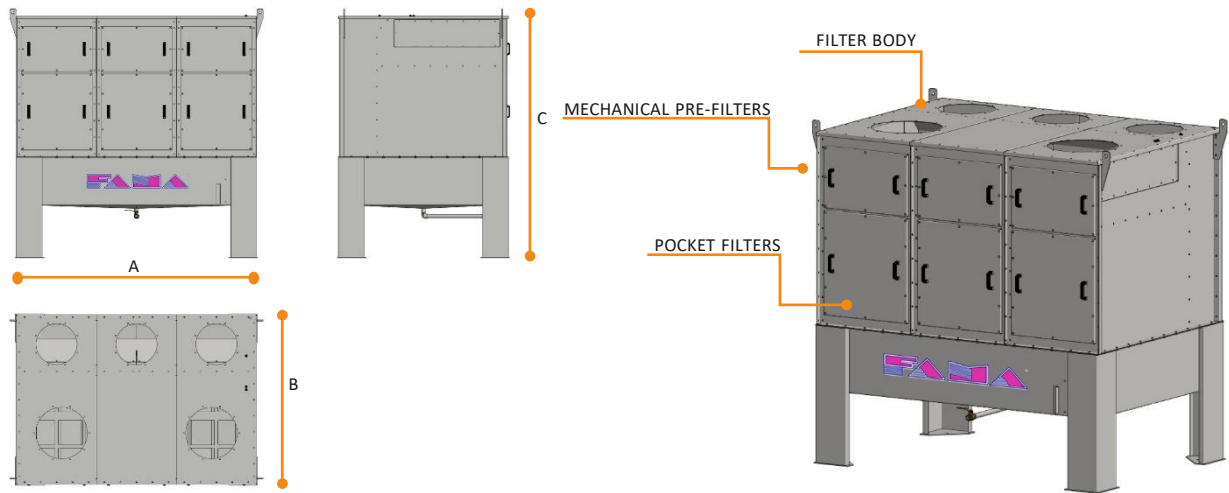

MODEL	T4 OIL	T6 OIL	T8 OIL	T10 OIL
A - LENGTH (mm)	1700	2500	3100	3900
B - WIDTH (mm)	1670	1670	1670	1670
C - HEIGHT (mm)	2400	2400	2400	2400
D - FILTRATION ELEMENTS(n°)	4	6	8	10
E - FILTERING SURFACE (m <sup>2</sup> )	107	160	215	268
F - FILTRATION RANGE (m <sup>3</sup> /h)	16000	24000	32000	40000
G - POWER (kW)	11÷18,5	15÷22	18,5÷30	22÷25